

Mechanical Film Thickness Gauges

for Coating Plants
and Laboratories

testing equipment for quality management

ERICHSEN

- **Wet Film Thickness Gauges
Model 234/333/433**
- **Dry Film Thickness Gauge
Model 233**

- **Thickness Gauge
for Wet and Dry Films
Model 296**

General

Film thickness measurement plays an essential part in the use and testing of paints and coating materials. The film thickness is a decisive factor in determining appearance, protective qualities and durability.

A film which is too thin will afford inadequate protection and reduced hiding power. For this reason, technical specifications stipulate minimum film thicknesses and regular controls must be carried out to ensure that these values are consistent.

On the other hand, an excessively thick film is the result of using too much coating material, causing costs to increase accordingly. Furthermore, thicker coatings do not always mean an improvement in properties: for example, they have an adverse affect on drying time.

The physical and mechanical properties of a coating are directly dependent on the film thickness. If meaningful testing is to be conducted, the film thickness must therefore be uniform.

Wet film thickness gauges are used to check freshly applied coatings and can also be used to calculate the resulting dry film thickness. If deviations from the specified value are detected, corrective measures can be taken immediately.

Dry film thickness gauges are used to check finished coatings.

Mechanical film thickness gauges provide a number of advantages:

- ◆ Handy, portable, and simple to operate, even by unskilled personnel.
Sturdy construction, direct reading.
- ◆ Measurements can be carried out on any surface. Since the system functions completely mechanically, substrates of glass, wood, metal or plastic are permissible.
- ◆ In comparison to other systems, mechanical film thickness gauges are favourably priced.

Wet Film Thickness Gauge, Model 234 in accordance with ISO 2808, ASTM D1212, BS 3900 : C5

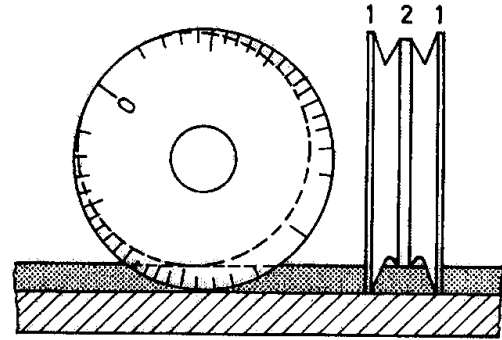

Fig. 1

Application

On all flat or uniformly curved (concave and convex) surfaces.

Test Principle

The disc-shaped measuring instrument (Fig. 1) is rolled over the wet film. During this process two knurled, concentric rims (1) roll across the substrate whilst an eccentrically positioned measuring rib (2) picks up coating material as soon as the distance of the rib from the rims is equivalent to the wet film thickness to be measured.

Design and Function

The hardened, precision-ground measuring disc of stainless steel is 50 mm in diameter and 11 mm thick. It features a freely rotating aluminium guide roller to enable the instrument to be rolled over the surface. Available in 8 different versions and measurement ranges (see order information). The read-out scale is engraved on one side around the periphery of the disc. Each instrument is supplied in a case.

Measuring Procedure

Measurement 1:

Grip the guide roller of the instrument between thumb and index finger and place on test surface so that contact is made on the side directly opposite the zero mark. Apply light pressure, roll instrument towards the zero mark and lift off.

Measurement 2: (cross check)

The instrument is positioned as instructed for measurement 1, but rolled in the opposite direction until it reaches the zero mark.

Read off wet film thickness from the scale at the point where wet film marking commences, compare with the opposite side and establish mean value.

Order Information

Order No.	Model	Measuring range	Read-off accuracy
0071.01.31	234 R/I	0 - 25 μm	1 μm
0071.02.31	234 R/II	0 - 50 μm	2 μm
0071.03.31	234 R/III	0 - 125 μm	5 μm
0071.04.31	234 R/IV	0 - 250 μm	10 μm
0071.05.31	234 R/V	0 - 500 μm	20 μm
0071.06.31	234 R/VI	500 - 1000 μm	20 μm
0071.07.31	234 R/VII	0 - 1000 μm	50 μm
0071.08.31	234 R/VIII	0 - 1500 μm	50 μm

**Wet Film Thickness Gauge, Model 333
acc. to Rossmann
in accordance with ISO 2808, BS 3900 : C5**

Application

On all flat and slightly curved surfaces, as long as the measuring instrument can be applied parallel to the axis of curvature.

Test Principle

The equally long teeth 1 and 12 of the comb-shaped measuring instrument (Fig. 2) penetrate the wet film to the substrate. Between these two end positions teeth 2 to 11 are formed at a progressively increasing distance from the substrate. Teeth 6 to 11 dip into the coating whilst teeth 2 to 5 do not touch the material. The measuring result is the mean value between tooth 5 and tooth 6.

Designs and Function

The teeth on two sides of a rectangular measuring instrument made of polished stainless steel plate are cut to achieve a progressively decreasing distance from the substrate. Engraved figures indicate the distance in μm from the base material.

Available in three different ranges (see order information).
The instrument is supplied in a synthetic leather pocket.

Measuring Procedure

The measuring blade with the assumed range of wet film thickness is placed on the test surface and held perpendicular. Applying slight pressure, a short "combing" movement is effected. The instrument is then lifted off vertically.

The wet film thickness is shown on the scale where the first tooth shows traces of coating material.

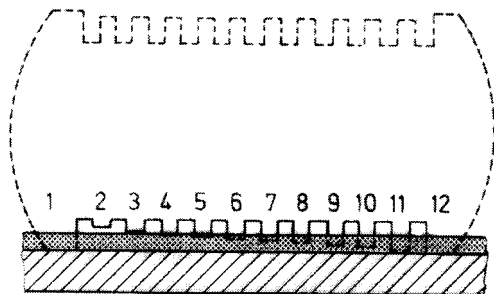

Fig. 2

Order Information			
Order No.	Model	Measuring range	Read-off accuracy
0091.01.31	333 I	0 - 120 μm	5 μm
0091.02.31	333 II	0 - 600 μm	25 μm
0091.03.31	333 III	0 - 1200 μm	50 μm

**Wet Film Thickness Gauge, Model 433
in accordance with ISO 2808, BS 3900 : C5**

Application

This easy-to-use comb-type measuring instrument can be used on any substrate.

Test Principle

Comparable with Model 233.

Design and function

Teeth are cut into all sides of a square stainless steel measuring blade at a progressively increasing distance from the substrate. Engraved figures indicate the distance in μm from the substrate.

The measuring range from 5 to 1500 μm is sub-divided as follows:

- ◆ 5 - 100 μm (5 μm scale division)
- ◆ 100 - 300 μm (10 μm scale division)
- ◆ 300 - 700 μm (20 μm scale division)
- ◆ 700 - 1500 μm (40 μm scale division)

By covering this extensive measuring range, the instrument is especially good value for the user.

The instrument is supplied in a synthetic leather pocket.

Excellent Measuring Accuracy

- ◆ Maximum deviation 3 μm (5 - 55 μm) or 5% from nominal value (60 - 1500 μm),
- ◆ Typical deviation less than 3 μm over the entire scale range.

Certifiable for QA Systems

Unlike the model 333 measuring blade, the model 433 film thickness gauge can be supplied - *at extra charge* - with a manufacturer's test certificate M to DIN 55 350 T 18. This certificate includes details of the values relating to the specific quality features of each individual instrument as determined in the ERICHSEN testing laboratory. It is no longer necessary for the user to carry out incoming tests.

Measuring Procedure

Comparable with Model 233.

Order Information	
Order No.	Product Name
0169.01.31	Wet film thickness gauge 433

**Dry Film Thickness Gauge, Model 233,
acc. to Rossmann**
in accordance with ISO 2808, ASTM D 1005,
BS 3900 : C5

Application

On all flat surfaces.

Test Principle

The difference in height (D) between the upper surface of the coating and an exposed area of the substrate is measured by means of the free-moving plunger (1) of a dial gauge, the two feet (2) of which are placed on the surface of the coating (Fig. 3).

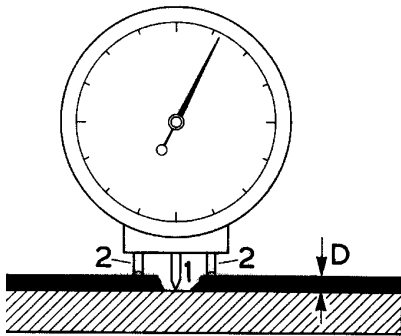

Fig. 3

Design and Function

The dial gauge is enclosed in a chrome-plated metal housing. The feet protruding from the base of the dial gauge and the plunger are protected by a cap. A notch in the side of this cap is used for adjusting the plunger which is set with the aid of a plane face glass plate, included in the scope of delivery. The dial gauge with accessories is supplied in a case.

Measuring Procedure

- 1) *Setting*
Remove protective cap and place the dial gauge vertically on the plane face glass plate. If the pointer is not at zero, the plunger can be turned with the aid of the notch in the cap until the zero reading is reached.
- 2) *Preparation of measuring point*
At the point where the measurement is to be made the coating should be carefully scraped off a 3 mm area down to the substrate.
- 3) *Measurement*
The dial gauge is placed in position so that the plunger touches the bare substrate. The dry film thickness can be read off at once in μm . In the case of soft coatings, a razor blade may be placed under the feet for support.

Order Information			
Order No.	Model	Measuring range	Read-off accuracy
0009.01.31	233	0 - 1000 μm	5 μm

**Wet and Dry Film Thickness Gauge,
Model 296, acc. to Rossmann**
in accordance with ISO 2808, ASTM D 1005,
BS 3900 : C5

Application

On all flat surfaces.

Test Principle

Differences in height (D) between the upper surface of a wet coating and the substrate are measured by way of the manually adjustable plunger (1) of a dial gauge which is supported on two feet (2) that penetrate the coating and rest on the substrate (Fig. 4).

Design and Function

In principle, this instrument is of a similar design to Model 233, except that there is a knurled screw at the top of the gauge housing with which the plunger, which otherwise moves freely, can be lowered and raised above the level of the feet.

The dial gauge is supplied in a case.

Measuring Procedure

Dry film is measured in exactly the same way as with the Model 233 instrument.

For measurements on wet films the plunger is initially raised by way of the knurled screw to obtain a reading on the pointer of 0.5 mm above the level of the feet.

The dial gauge is then placed on the wet film so that the feet rest on the substrate. The plunger is lowered slowly using the knurled screw until it just touches the surface of the wet film. The film thickness in μm can be read off on the dial.

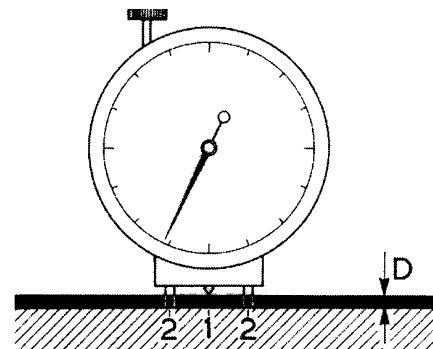

Fig. 4

Order Information			
Order No.	Model	Measuring range	Read-off accuracy
0084.01.31	296	0 - 500 μm	5 μm

Subject to technical modifications. TB/BA E - IX/98